

**FN-PSYA**

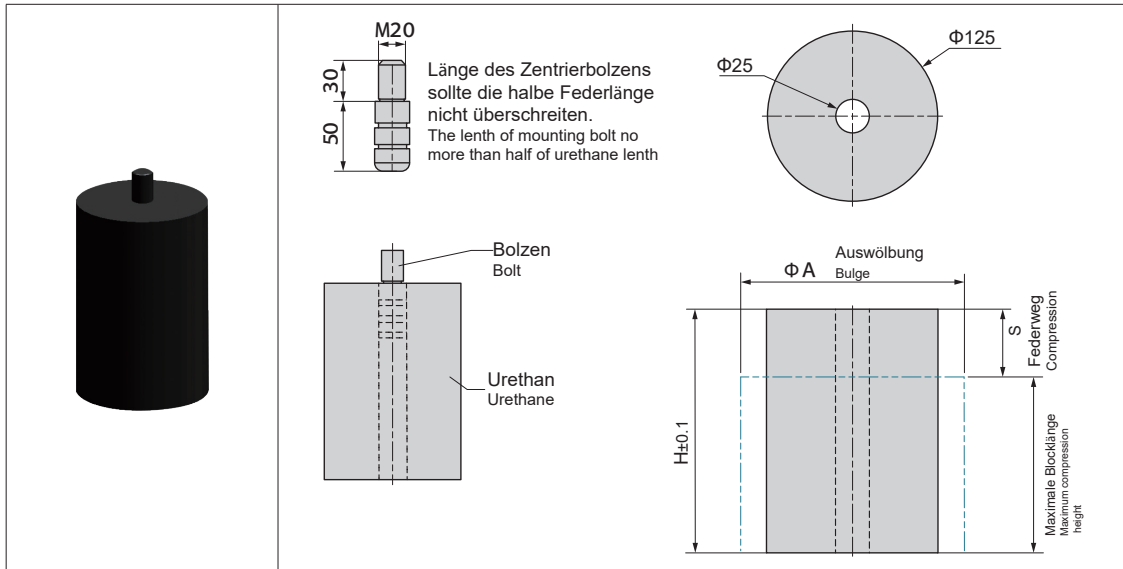

Material: Urethan  
 Härte: Shore A90±2

Material: Urethane  
 Hardness: Shore A90±2

Bestell-Nr Catalog No.	H	S	h
FN-PSYA125-125	125	17.3	107.7
FN-PSYA125-140	140	22	118
FN-PSYA125-150	150	27.5	122.5
FN-PSYA125-160	160	34.5	125.5
FN-PSYA125-180	180	38.5	141.5
FN-PSYA125-190	190	41.3	148.7
FN-PSYA125-200	200	44	156
FN-PSYA125-215	215	49.5	165.5
FN-PSYA125-225	225	52.3	172.7

s(mm) Federweg Compression	Resultierende Kraft (N) bei Federweg Force (N) at compression								
	125	140	150	160	180	190	200	215	225
5	6227	5723	4448	4003	3144	2669	2218	1779	1335
10	7800	6800	6000	5500	5000	4500	4000	3500	2800
15	13234	12010	9786	8896	7562	7117	5782	5338	4893
20	17500	15500	14000	13200	11000	10700	10500	9800	9000
25		25200	21350	19571	17347	16458	13789	12899	11500
30			23500	21300	19000	17500	16000	15000	14000
35				25570	23130	21350	18237	16903	15568
40					26400	25200	23500	21000	20000
45						32915	28025	24354	23575
50								29000	28200
55									33360

**Bestellnummer / Order Number**

	Bestellnr. / Catalog No.	∅	-	H
	<b>FN-PSYA</b>	<b>125</b>	-	<b>160</b>

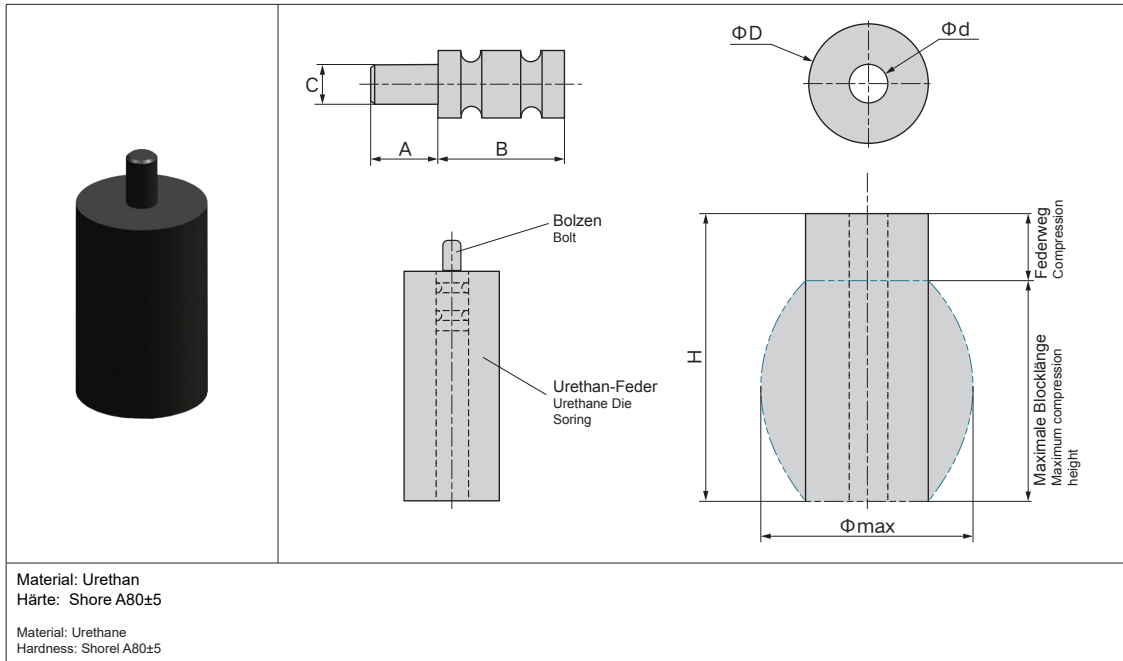

**GM-PSYA**

	A	B	C	Zylinderdurchmesser D Cylinder diameter	Φmax
Bolt	12.5	38	M6x1.0	30	40
	16	38	M10x1.5	40	50
	20	38	M12x1.75	50	65
	20	38	M12x1.75	63	80
	30	50	M20x2.5	80	100
	30	50	M20x2.5	100	125
	30	50	M20x2.5	125	160
	30	50	M20x2.5	150	190

Bestell-Nr. Catalog No.	ΦD	Φd	H	h Maximale Blocklänge / Maximum compression height	Φmax
GM-PSYA30-32	30	8	32	19	38
GM-PSYA30-40			40	24	
GM-PSYA30-50			50	30	
GM-PSYA30-63			63	38	
GM-PSYA30-80			80	48	
GM-PSYA30-100			100	60	
GM-PSYA40-32	40	16	32	19	50
GM-PSYA40-40			40	24	
GM-PSYA40-50			50	30	
GM-PSYA40-63			63	38	
GM-PSYA40-80			80	48	
GM-PSYA40-100			100	60	
GM-PSYA50-32	50	20	32	19	64
GM-PSYA50-40			40	24	
GM-PSYA50-50			50	30	
GM-PSYA50-63			63	38	
GM-PSYA50-80			80	48	
GM-PSYA50-100			100	60	
GM-PSYA50-125			125	75	
GM-PSYA63-40	63	20	40	24	79
GM-PSYA63-50			50	30	
GM-PSYA63-63			63	38	
GM-PSYA63-80			80	48	
GM-PSYA63-100			100	60	
GM-PSYA63-125			125	75	
GM-PSYA63-150			150	90	
GM-PSYA80-63	80	25	63	38	104
GM-PSYA80-80			80	48	
GM-PSYA80-100			100	60	
GM-PSYA80-125			125	75	
GM-PSYA80-140			140	84	
GM-PSYA80-150			150	90	
GM-PSYA80-160			160	96	
GM-PSYA80-180			180	108	

**Bestellnummer / Order Number**

Bestellnr. / Catalog No.

ØD - H

**GM-PSYA**
**50 - 63**
